

LESA® DOMINATOR Plate Dowel 75/10

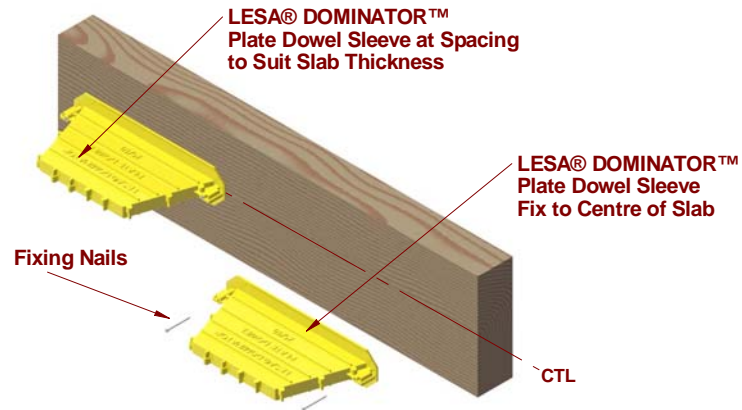

STEP 1
Mark the form for slab centre and Dominator Plate Dowel spacing. Using nails provided fix the Dominator Dowel Sleeve to the form

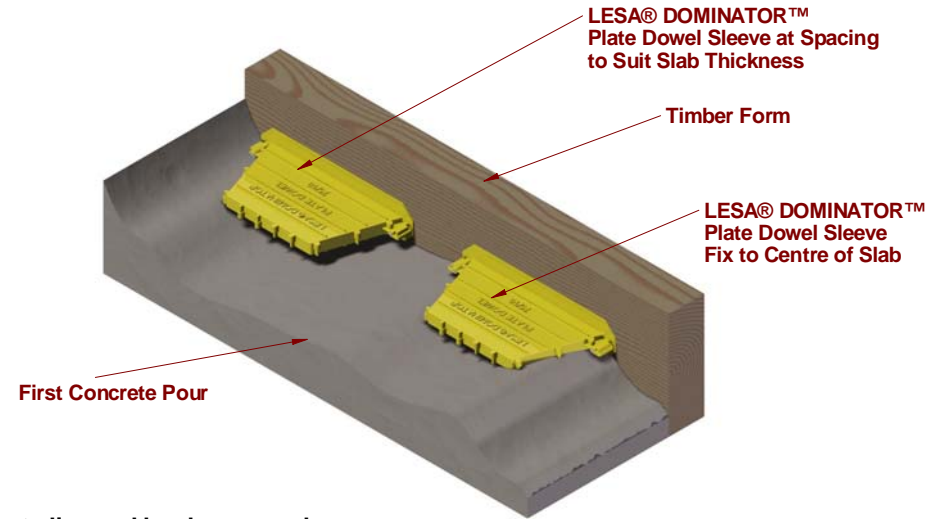

STEP 2
Set the form to line and level as normal.
Place and finish concrete
Edge of slab must be vibrated to consolidate concrete around the Dominator Sleeve.
NOTE! Ensure vibrator does not have contact with plastic sleeves

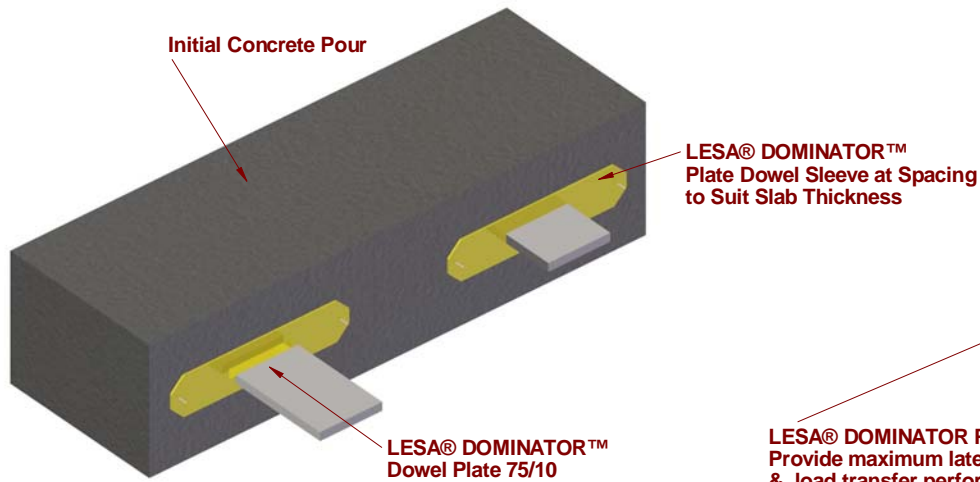

STEP 3
Strip the form.
Forms should be cleaned and stored for reuse.
Insert the 75/10 Plate Dowel when required prior to concrete pour.

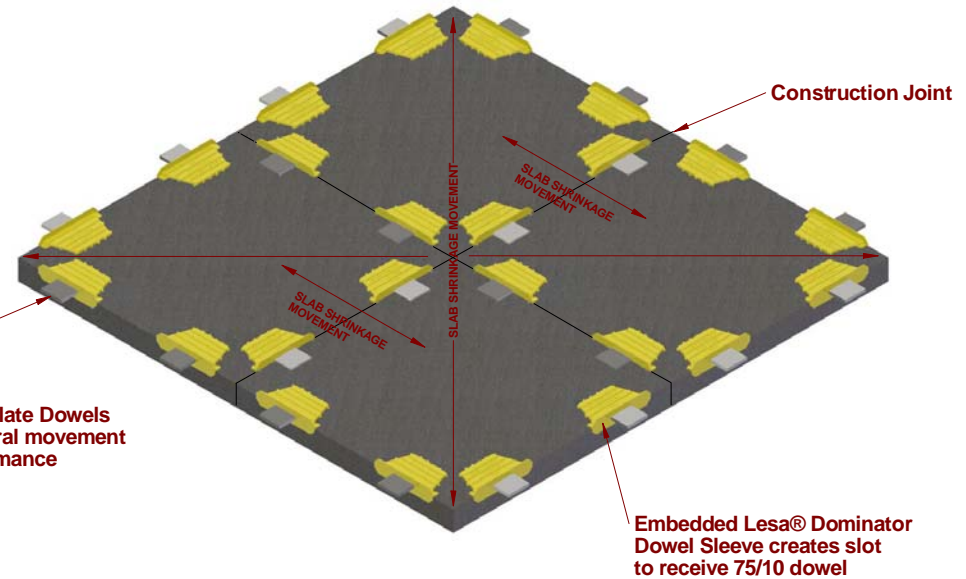

SECTION VIEWS Showing Successive Slab Build Using Dominator Sleeves and Dowels.

SPECIFICATION : LESA® DOMINATOR PLATE DOWEL
 * MINIMIZES CONCRETE BEARING STRESS AND REDUCES DEFLECTION ACROSS JOINT
 * ALLOWS THE SLAB TO SHRINK WITHOUT RESTRAINT
 * ELIMINATES DOWEL MISALIGNMENT AND REDUCES STRESSES
 * IMPROVES FORM REMOVAL (REUSE INCREASED)
 * LESA® DOMINATOR PLATE DOWELS MUST BE INSTALLED USING A FULL DEPTH FORM



LESA SYSTEMS
ENGINEERED CONCRETE FLOOR SYSTEMS
www.lesasystems.com.au
Ph: 1300 04 LESA (aus)
www.lesasystems.co.nz
PH: 0800 74 LESA (nz)

THIS DOCUMENT MUST NOT BE COPIED NOR THE CONTENTS PASSED ON TO ANY THIRD PARTY WITHOUT THE PRIOR CONSENT OF LESA® SYSTEMS
 DRAWN BY **SMDS**
 DATE CREATED **10/07/2008**
 DO NOT SCALE DRAWING

PROJECT **LESA® DOMINATOR Plate Dowel 75/10**
 TITLE **LESA® DOMINATOR Plate Dowel 75/10**
 DWG # **LS-D-PD-75/10**
 UNLESS OTHERWISE SPECIFIED DIMENSIONS ARE IN MM
 THIRD ANGLE PROJECTION

LESA® DOMINATOR Plate Dowel 75/10

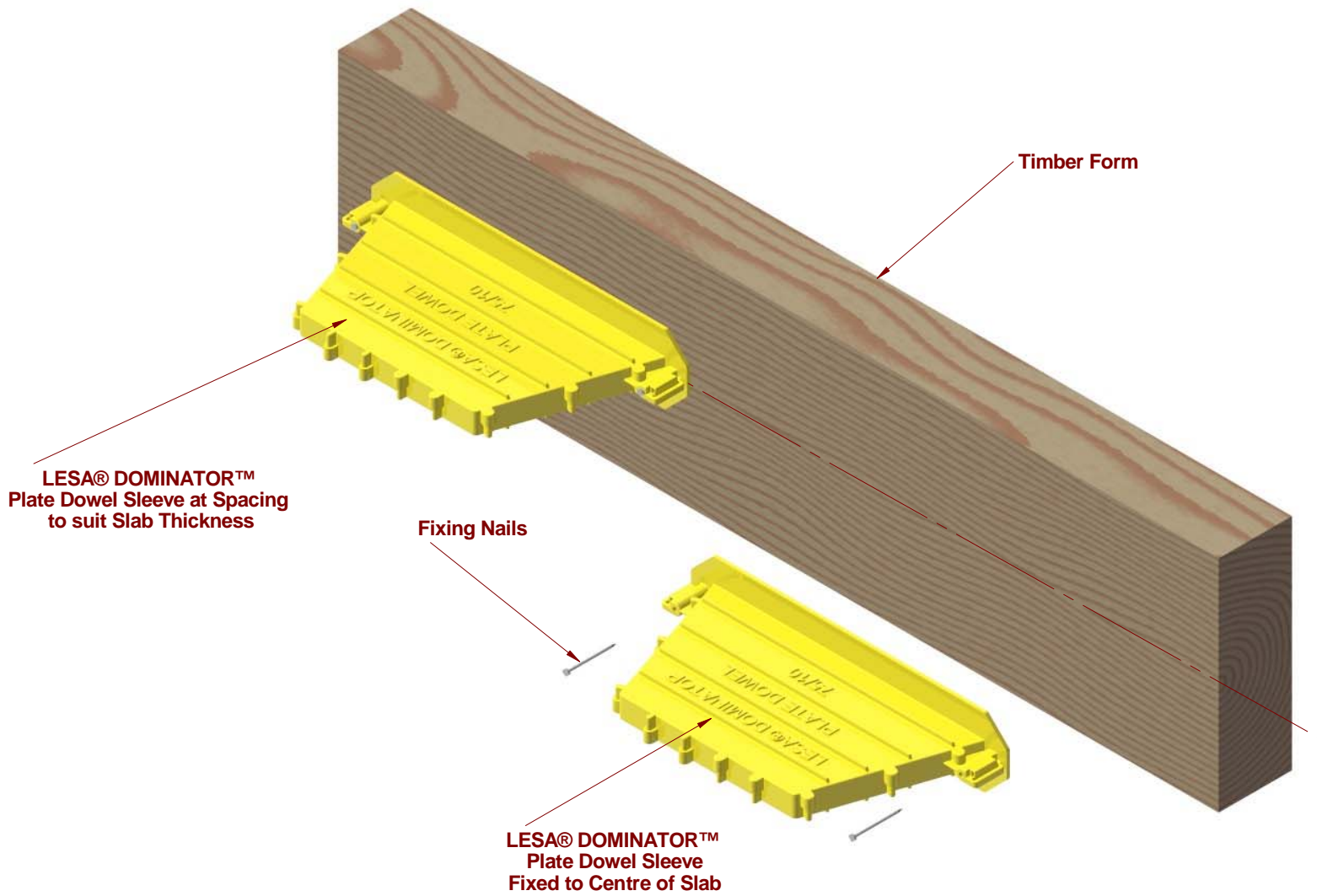

STEP 1

Mark the form for slab centre and Dominator Plate Dowel spacing. Using nails provided fix the Dominator Dowel Sleeve to the form

SPECIFICATION : LESA® DOMINATOR PLATE DOWEL

- * MINIMIZES CONCRETE BEARING STRESS AND REDUCES DEFLECTION ACROSS JOINT
- * ALLOWS THE SLAB TO SHRINK WITHOUT RESTRAINT
- * ELIMINATES DOWEL MISALIGNMENT AND REDUCES STRESSES
- * IMPROVES FORM REMOVAL (REUSE INCREASED)
- * LESA® DOMINATOR PLATE DOWELS MUST BE INSTALLED USING A FULL DEPTH FORM



LESA SYSTEMS
ENGINEERED CONCRETE FLOOR SYSTEMS

www.lesasystems.com.au
Ph: 1300 04 LESA (aus)

www.lesasystems.co.nz
PH: 0800 74 LESA (nz)

THIS DOCUMENT MUST NOT BE
COPIED NOR THE CONTENTS
PASSED ON TO ANY THIRD PARTY
WITHOUT THE PRIOR CONSENT OF
LESA® SYSTEMS

DRAWN BY **SMDS**
DATE
CREATED **10/07/2008**

DO NOT SCALE
DRAWING

UNLESS OTHERWISE SPECIFIED
DIMENSIONS ARE IN MM

THIRD ANGLE PROJECTION

PROJECT **LESA® DOMINATOR Plate Dowel 75/10**

TITLE **LESA® DOMINATOR Plate Dowel 75/10**

DWG # **LS-D-PD-75/10**

SHEET 2 OF 6

LESA® DOMINATOR Plate Dowel 75/10

LESA® DOMINATOR™
Plate Dowel Sleeve at Spacing
to suit Slab Thickness

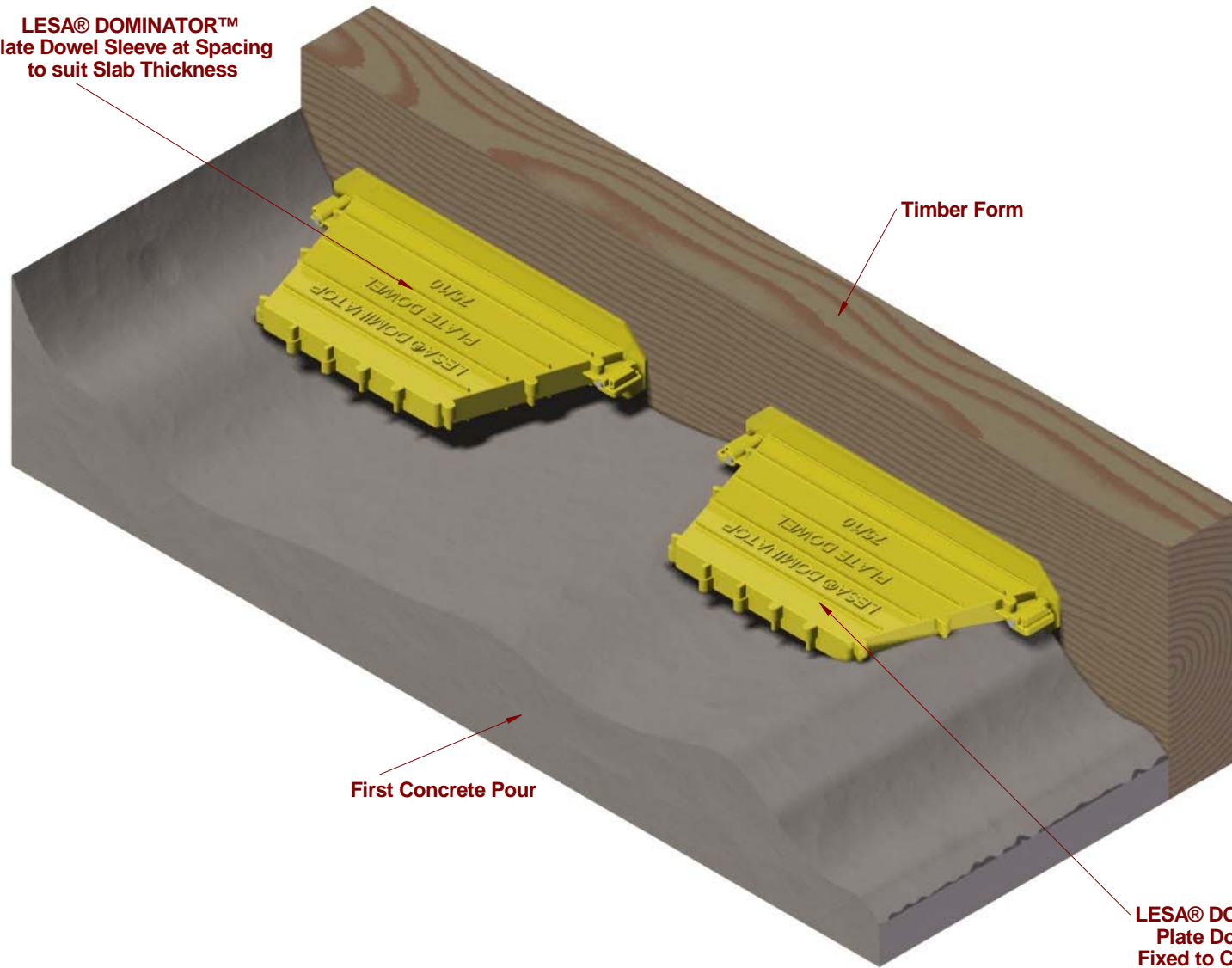

Timber Form

First Concrete Pour

LESA® DOMINATOR™
Plate Dowel Sleeve
Fixed to Centre of Slab

STEP 2

Set the form to line and level as normal.

Place and finish concrete

Edge of slab must be vibrated to consolidate concrete around the Dominator Sleeve.

NOTE! Ensure vibrator does not have contact with plastic sleeves

SPECIFICATION : LESA® DOMINATOR PLATE DOWEL

- * MINIMIZES CONCRETE BEARING STRESS AND REDUCES DEFLECTION ACROSS JOINT
- * ALLOWS THE SLAB TO SHRINK WITHOUT RESTRAINT
- * ELIMINATES DOWEL MISALIGNMENT AND REDUCES STRESSES
- * IMPROVES FORM REMOVAL (REUSE INCREASED)
- * LESA® DOMINATOR PLATE DOWELS MUST BE INSTALLED USING A FULL DEPTH FORM



LESA SYSTEMS
ENGINEERED CONCRETE FLOOR SYSTEMS

www.lesasystems.com.au
Ph: 1300 04 LESA (aus)

www.lesasystems.co.nz
PH: 0800 74 LESA (nz)

THIS DOCUMENT MUST NOT BE
COPIED NOR THE CONTENTS
PASSED ON TO ANY THIRD PARTY
WITHOUT THE PRIOR CONSENT OF
LESA® SYSTEMS

DRAWN BY **SMDS**
DATE
CREATED **10/07/2008**

DO NOT SCALE
DRAWING

UNLESS OTHERWISE SPECIFIED
DIMENSIONS ARE IN MM

THIRD ANGLE PROJECTION

PROJECT **LESA® DOMINATOR Plate Dowel 75/10**

TITLE **LESA® DOMINATOR Plate Dowel 75/10**

DWG # **LS-D-PD-75/10**

SHEET 3 OF 6

LESA® DOMINATOR Plate Dowel 75/10

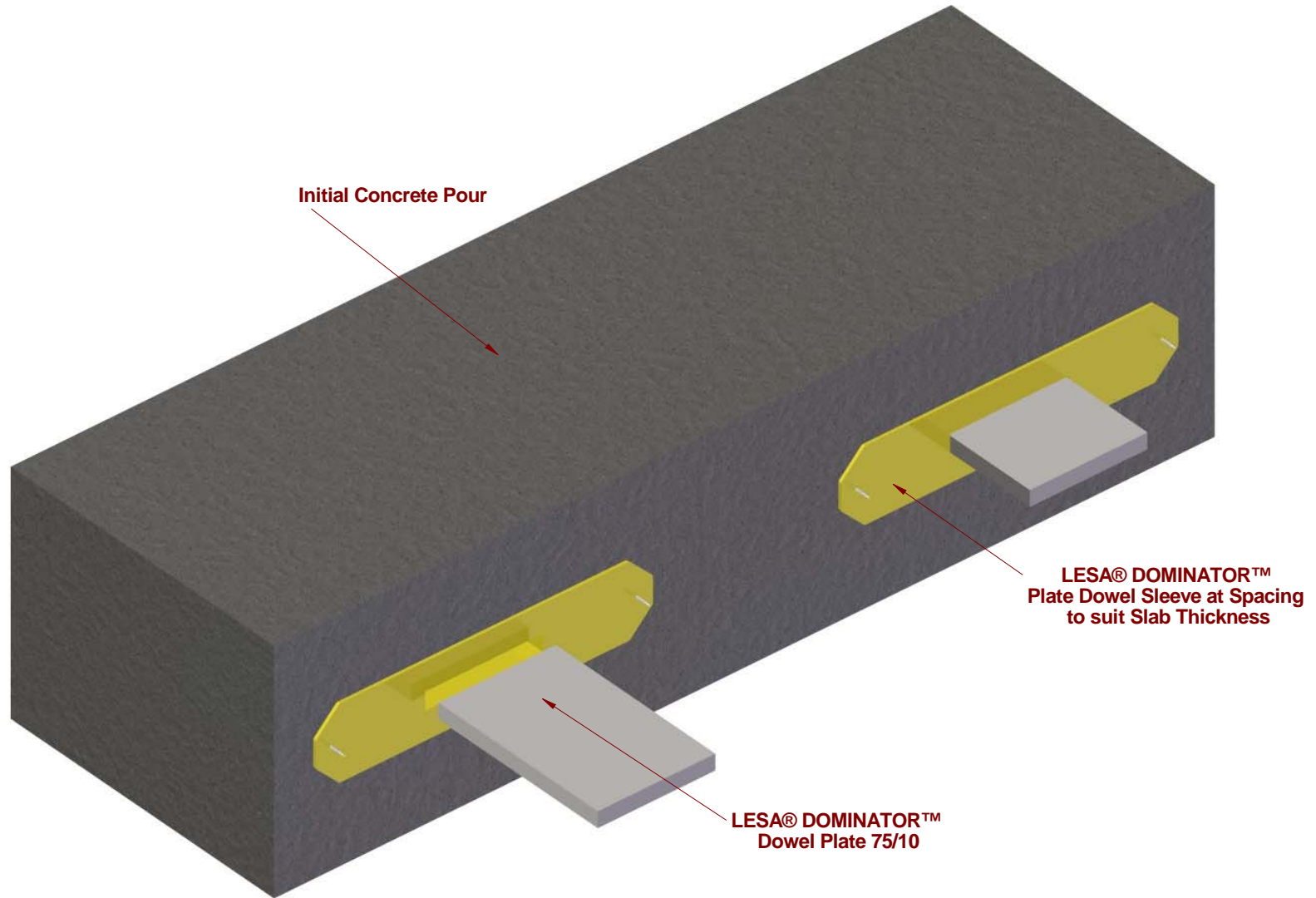

STEP 3
Strip the form.
 Forms should be cleaned and stored for reuse.
 Insert the 75/10 Plate Dowel when required prior to concrete pour.

- SPECIFICATION : LESA® DOMINATOR PLATE DOWEL**
- * MINIMIZES CONCRETE BEARING STRESS AND REDUCES DEFLECTION ACROSS JOINT
 - * ALLOWS THE SLAB TO SHRINK WITHOUT RESTRAINT
 - * ELIMINATES DOWEL MISALIGNMENT AND REDUCES STRESSES
 - * IMPROVES FORM REMOVAL (REUSE INCREASED)
 - * LESA® DOMINATOR PLATE DOWELS MUST BE INSTALLED USING A FULL DEPTH FORM



LESA SYSTEMS
 ENGINEERED CONCRETE FLOOR SYSTEMS
www.lesasystems.com.au
 Ph: 1300 04 LESA (aus)
www.lesasystems.co.nz
 PH: 0800 74 LESA (nz)

THIS DOCUMENT MUST NOT BE
 COPIED NOR THE CONTENTS
 PASSED ON TO ANY THIRD PARTY
 WITHOUT THE PRIOR CONSENT OF
 LESA® SYSTEMS

DRAWN BY **SMDS**
 DATE
 CREATED **10/07/2008**

PROJECT **LESA® DOMINATOR Plate Dowel 75/10**
 TITLE **LESA® DOMINATOR Plate Dowel 75/10**

DWG # LS-D-PD-75/10

DO NOT SCALE
 DRAWING

UNLESS OTHERWISE SPECIFIED
 DIMENSIONS ARE IN MM

THIRD ANGLE PROJECTION

SHEET 4 OF 6

LESA® DOMINATOR Plate Dowel 75/10

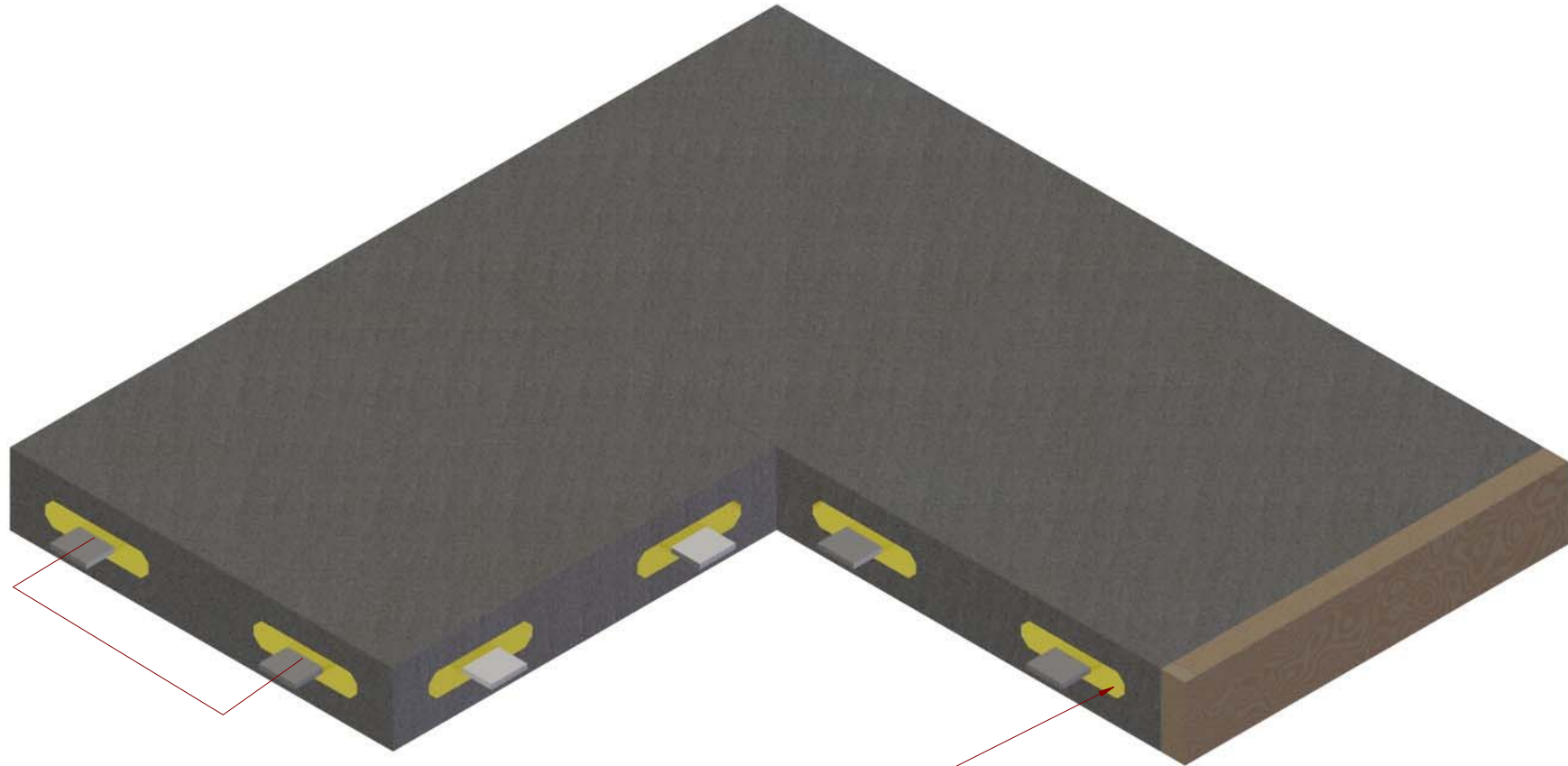

Embedded Lesa® Dominator Dowel Sleeve creates slot to receive 75/10 dowel

SPECIFICATION : LESA® DOMINATOR PLATE DOWEL

- * MINIMIZES CONCRETE BEARING STRESS AND REDUCES DEFLECTION ACROSS JOINT
- * ALLOWS THE SLAB TO SHRINK WITHOUT RESTRAINT
- * ELIMINATES DOWEL MISALIGNMENT AND REDUCES STRESSES
- * IMPROVES FORM REMOVAL (REUSE INCREASED)
- * LESA® DOMINATOR PLATE DOWELS MUST BE INSTALLED USING A FULL DEPTH FORM



LESA SYSTEMS
ENGINEERED CONCRETE FLOOR SYSTEMS

www.lesasystems.com.au
Ph: 1300 04 LESAs (aus)

www.lesasystems.co.nz
PH: 0800 74 LESAs (nz)

THIS DOCUMENT MUST NOT BE COPIED NOR THE CONTENTS PASSED ON TO ANY THIRD PARTY WITHOUT THE PRIOR CONSENT OF LESAs SYSTEMS

DRAWN BY **SMDS**
DATE
CREATED **10/07/2008**

DO NOT SCALE DRAWING

UNLESS OTHERWISE SPECIFIED DIMENSIONS ARE INMM

 THIRD ANGLE PROJECTION

PROJECT **LESA® DOMINATOR Plate Dowel 75/10**

TITLE **LESA® DOMINATOR Plate Dowel 75/10**

DWG # **LS-D-PD-75/10**

SHEET 5 OF 6

LESA® DOMINATOR Plate Dowel 75/10

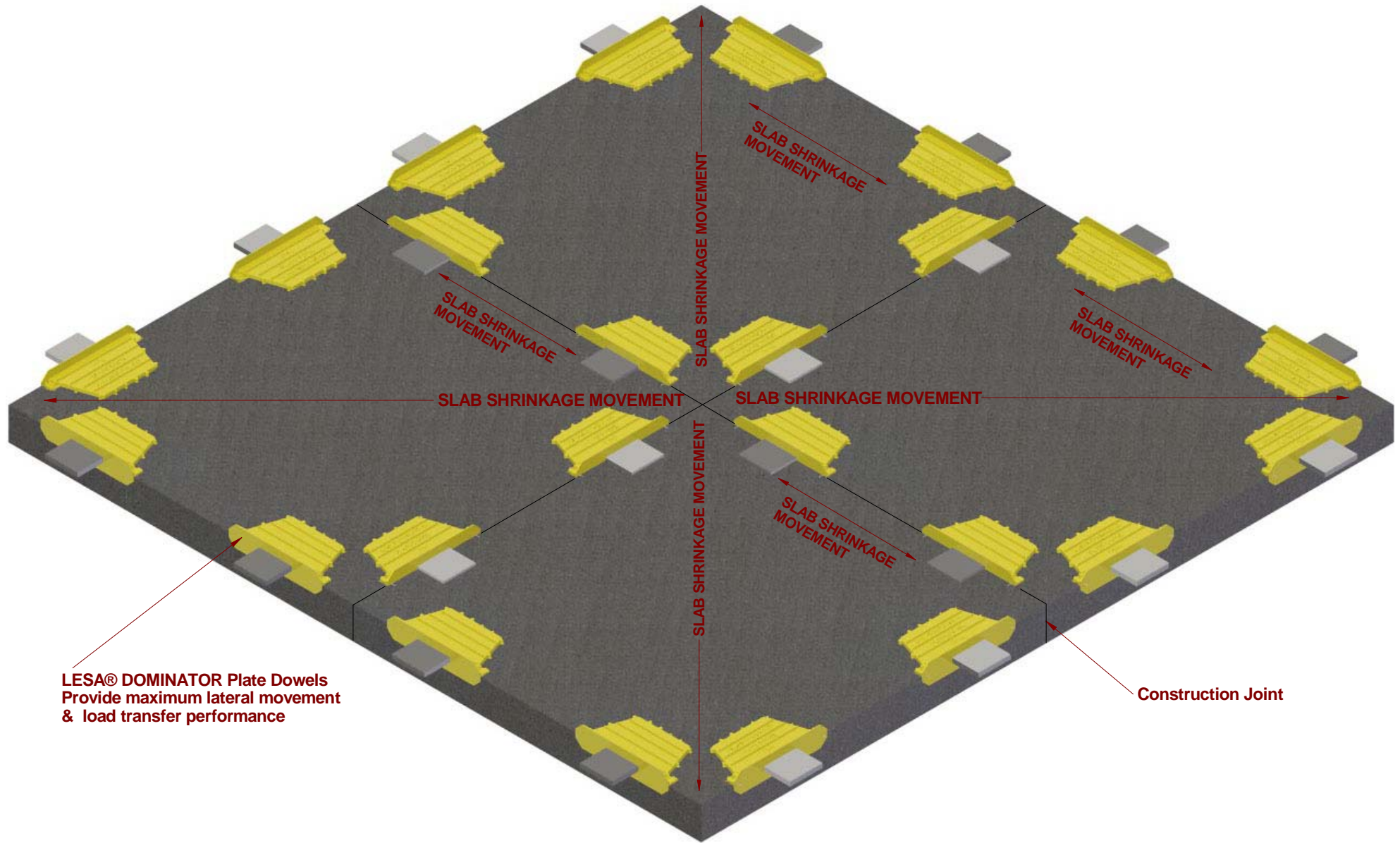

LESA® DOMINATOR Plate Dowels
Provide maximum lateral movement
& load transfer performance

Construction Joint

SECTION VIEWS
Showing concrete cutaway to reveal Dominator Sleeves and Dowels.

SPECIFICATION : LESA® DOMINATOR PLATE DOWEL

- * MINIMIZES CONCRETE BEARING STRESS AND REDUCES DEFLECTION ACROSS JOINT
- * ALLOWS THE SLAB TO SHRINK WITHOUT RESTRAINT
- * ELIMINATES DOWEL MISALIGNMENT AND REDUCES STRESSES
- * IMPROVES FORM REMOVAL (REUSE INCREASED)
- * LESA® DOMINATOR PLATE DOWELS MUST BE INSTALLED USING A FULL DEPTH FORM



LESA SYSTEMS
ENGINEERED CONCRETE FLOOR SYSTEMS

www.lesasystems.com.au
Ph: 1300 04 LESA (aus)

www.lesasystems.co.nz
PH: 0800 74 LESA (nz)

THIS DOCUMENT MUST NOT BE
COPIED NOR THE CONTENTS
PASSED ON TO ANY THIRD PARTY
WITHOUT THE PRIOR CONSENT OF
LESA® SYSTEMS

DRAWN BY **SMDS**
DATE
CREATED **10/07/2008**

DO NOT SCALE
DRAWING

UNLESS OTHERWISE SPECIFIED
DIMENSIONS ARE IN MM

THIRD ANGLE PROJECTION

PROJECT **LESA® DOMINATOR Plate Dowel 75/10**

TITLE **LESA® DOMINATOR Plate Dowel 75/10**

DWG # **LS-D-PD-75/10**

SHEET 6 OF 6